

Aluminum Capacitors Standard - 85 °C Snap-in

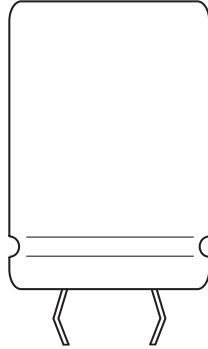

Component outlines.

FEATURES

- Polarized aluminium electrolytic capacitors
- Small dimension
- High C•U
- Long useful life 3000h / 85 °C

APPLICATIONS

- General use audio/video systems, industrial electronics
- Smoothing, filtering
- Standard and switch mode power supplies

QUICK REFERENCE DATA			
DESCRIPTION	UNIT	LOW VOLTAGE	HIGH VOLTAGE
Nominal case size (∅D × L)	mm	22 x 20 to 40 x 60	
Rated capacitance range C _R	μF	1200 to 100000	47 to 1800
Capacitance tolerance	%	± 20	
Rated voltage range	V	6.3 to 100	160 to 500
Category temperature range	°C	- 40 to + 85 (U _R ≥ 400 V: - 25 to + 85)	
Endurance test at upper category temperature	h	2000	
Useful life at 85 °C and I _R applied	h	3000	
Useful life at 40 °C and I _R applied	h	70000	
Failure rate (0.8 U _R , 40 °C)	10 ⁻⁹ /h	≤ 60	
Based on sectional specifications		IEC 60384-4, EN 130300	
Climatic category IEC 60 068		40/85/56	

SELECTION CHART FOR C_R, U_R AND RELEVANT NOMINAL CASE SIZES (∅D × L in mm)								
C _R (μF)	U _R (V) ≤ 100 V							
	6.3	10	16	25	35	50	63	100
1200	-	-	-	-	-	-	-	22 x 30 25 x 25
1500	-	-	-	-	-	-	-	25 x 25 25 x 30 30 x 25
1800	-	-	-	-	-	-	22 x 25	22 x 40 25 x 35 30 x 30
2200	-	-	-	-	-	22 x 25	22 x 30 25 x 25	22 x 45 25 x 40 30 x 30
2700	-	-	-	-	-	-	22 x 35 25 x 30	25 x 45 30 x 25 35 x 30

SELECTION CHART FOR C_R, U_R AND RELEVANT NOMINAL CASE SIZES ($\varnothing D \times L$ in mm)								
C_R (μF)	$U_R (V) \leq 100 V$							
	6.3	10	16	25	35	50	63	100
3300	-	-	-	-	-	22 x 30 25 x 25	22 x 35 25 x 30 30 x 25	25 x 50 30 x 40 35 x 35
3900	-	-	-	-	-	-	22 x 40 25 x 35 30 x 30	30 x 45 35 x 40
4700	-	-	-	-	22 x 30 25 x 25	22 x 40 25 x 35 30 x 25 35 x 25	22 x 50 25 x 40 30 x 35 35 x 30	30 x 50 35 x 40
5600	-	-	-	22 x 25	22 x 35 25 x 30	22 x 45 25 x 40 30 x 30 35 x 25	25 x 45 30 x 35 35 x 30	35 x 45 40 x 40
6800	-	-	-	22 x 30 25 x 25	22 x 40 25 x 30 30 x 25	22 x 50 25 x 40 30 x 25 35 x 30	25 x 50 30 x 40 35 x 30	40 x 50
8200	-	-	-	22 x 35 25 x 30	22 x 45 25 x 35 30 x 30	25 x 50 30 x 40 35 x 30	30 x 45 35 x 35	40 x 50
10000	-	-	22 x 25	22 x 40 25 x 30 30 x 25	22 x 50 25 x 40 30 x 30	30 x 45 35 x 35	30 x 50 35 x 40	-
12000	-	22 x 25	22 x 30 25 x 25	22 x 45 25 x 35 30 x 30	25 x 45 30 x 35 35 x 30	30 x 50 35 x 40	35 x 45 40 x 40	-
15000	22 x 25	22 x 30 25 x 25	22 x 25 25 x 30 30 x 25	22 x 50 25 x 40 30 x 25	30 x 40 35 x 35	35 x 45	-	-
18000	22 x 30 25 x 25	22 x 35 25 x 25	22 x 40 25 x 35 30 x 30	25 x 45 30 x 35 35 x 30	30 x 45 35 x 40	35 x 50 40 x 40	-	-
22000	22 x 35 25 x 25	22 x 40 25 x 30 30 x 25	22 x 50 25 x 40 30 x 30	30 x 45 35 x 35	35 x 45 40 x 40	40 x 50 40 x 60	-	-
27000	22 x 40 25 x 30 30 x 25	22 x 45 25 x 35 30 x 30	25 x 45 30 x 35 35 x 25	30 x 50 35 x 40	40 x 50	-	-	-
33000	22 x 45 25 x 35 30 x 30	22 x 50 25 x 40 30 x 30 35 x 25	30 x 40 35 x 30	35 x 45 40 x 40	40 x 50	-	-	-
39000	22 x 50 25 x 40 30 x 30 35 x 25	25 x 45 30 x 35 35 x 30	30 x 45 35 x 35	-	-	-	-	-
47000	25 x 45 30 x 35 35 x 30	25 x 50 30 x 40 35 x 30	30 x 50 35 x 40	-	-	-	-	-
56000	25 x 50 30 x 40 35 x 30	30 x 45 35 x 35	35 x 45 40 x 40	-	-	-	-	-
68000	30 x 45 35 x 35	35 x 40	35 x 50 40 x 50	-	-	-	-	-
100000	35 x 45 40 x 40	40 x 50	40 x 60	-	-	-	-	-

Special values/dimensions on request.



Aluminum Capacitors
Standard - 85 °C Snap-in

Vishay Roederstein

SELECTION CHART FOR C_R, U_R AND RELEVANT NOMINAL CASE SIZE (∅D x L in mm)							
C _R (μF)	U _R (V) > 100 V						
	160	200	250	350	400	450	500
47	-	-	-	-	-	22 x 20	-
56	-	-	-	-	-	22 x 20	-
68	-	-	-	-	22 x 20	22 x 25	22 x 30 25 x 20
82	-	-	-	22 x 20	22 x 25 25 x 20	22 x 20 25 x 25 30 x 20	22 x 35 25 x 30
100	-	-	-	22 x 25 25 x 20	22 x 30 25 x 25 30 x 20	22 x 35 25 x 30 30 x 25 35 x 20	22 x 40 25 x 35
120	-	-	-	22 x 30 25 x 25 30 x 20	22 x 30 25 x 25 30 x 20	22 x 40 25 x 35 30 x 25 35 x 20	25 x 40
150	-	22 x 25 25 x 20	-	22 x 35 25 x 30 30 x 20	22 x 35 25 x 30 30 x 25 35 x 20	22 x 50 25 x 40 30 x 30 35 x 25	30 x 35
180	-	22 x 20	22 x 25 25 x 20	22 x 40 25 x 35 30 x 25 35 x 20	22 x 40 25 x 35 30 x 25 35 x 25	25 x 45 30 x 25 35 x 25	30 x 40
220	22 x 20	22 x 25 25 x 20	22 x 25 25 x 25 30 x 20	22 x 45 25 x 35 30 x 30 35 x 25	22 x 45 25 x 40 30 x 30 35 x 25	25 x 50 30 x 40 35 x 30	30 x 45
270	22 x 25 25 x 20	22 x 25 25 x 25 30 x 20	22 x 30 25 x 25 30 x 20	25 x 45 30 x 35 35 x 25	25 x 45 30 x 35 35 x 30	30 x 45 35 x 35	35 x 45
330	22 x 25 25 x 20	22 x 30 25 x 25 30 x 20	22 x 35 25 x 30 30 x 25 35 x 20	25 x 50 30 x 40 35 x 30	25 x 50 30 x 40 35 x 30	30 x 50 35 x 40	35 x 50
390	22 x 25 25 x 25 30 x 20	22 x 30 25 x 25 30 x 25 35 x 20	22 x 40 25 x 30 30 x 25 35 x 20	30 x 45 35 x 35	30 x 45 35 x 35	35 x 45	-
470	22 x 30 25 x 25 30 x 20	22 x 35 25 x 30 30 x 25 35 x 20	22 x 45 25 x 35 30 x 30 35 x 25	30 x 50 35 x 40	30 x 50 35 x 40	35 x 50 40 x 40	40 x 50
560	22 x 35 25 x 30 30 x 25 35 x 20	22 x 40 25 x 35 30 x 25 35 x 25	22 x 50 25 x 40 30 x 30 35 x 25	35 x 45	35 x 45 40 x 40	40 x 50	40 x 60
680	22 x 40 25 x 30 30 x 25 35 x 20	22 x 45 25 x 40 30 x 30 35 x 25	25 x 45 30 x 35 35 x 30	35 x 50 40 x 40	40 x 50	40 x 60	40 x 60
820	22 x 45 25 x 35 30 x 30 35 x 25	22 x 50 25 x 45 30 x 35 35 x 30	30 x 40 35 x 35	40 x 50	40 x 60	-	-
1000	22 x 50 25 x 40 30 x 30 35 x 25	30 x 40 35 x 30	30 x 45 35 x 40	-	-	-	-
1200	25 x 45 30 x 35 35 x 30	30 x 45 35 x 35	35 x 45 40 x 40	-	-	-	-
1500	30 x 40 35 x 35	30 x 50 35 x 40	35 x 50 40 x 50	-	-	-	-
1800	35 x 40 40 x 40	35 x 45 40 x 40	40 x 60	-	-	-	-

Special values/dimensions on request.

DIMENSIONS in millimeters **AND AVAILABLE FORMS**

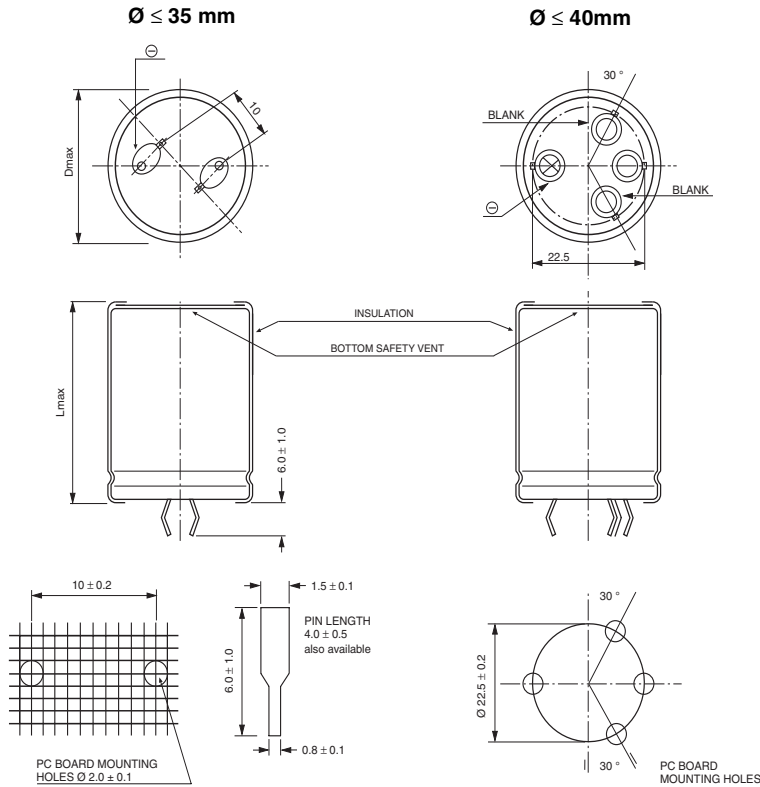

DIMENSION in millimeters AND PACKING QUANTITIES		
Normal case size $\text{ØD} \times L$	Maximum size $D_{\text{max}} \times L_{\text{max}}$	Packaging quantity pcs
22 x 20 22 x 25 22 x 30 22 x 35 22 x 40 22 x 45	23 x 22 23 x 27 23 x 32 23 x 37 23 x 42 23 x 47	200
25 x 20 25 x 25 25 x 30 25 x 35 25 x 40 25 x 50	26.4 x 22 26.4 x 27 26.4 x 32 26.4 x 37 26.4 x 42 26.4 x 52	150
30 x 20 30 x 25 30 x 30 30 x 35 30 x 40 30 x 45 30 x 50	31 x 22 31 x 27 31 x 32 31 x 37 31 x 42 31 x 47 31 x 52	100
35 x 20 35 x 25 35 x 30 35 x 35 35 x 40 35 x 45 35 x 50	36 x 22 36 x 27 36 x 32 36 x 37 36 x 42 36 x 47 36 x 52	70
40 x 40 40 x 50 40 x 60	41 x 42 41 x 52 41 x 62	50



Aluminum Capacitors
Standard - 85 °C Snap-in

Vishay Roederstein

ELECTRICAL DATA	
SYMBOL	DESCRIPTION
C _R	Rated capacitance at 120 Hz
U _R	Rated voltage
Tan δ	Dissipation factor at 120 Hz
R _{ESR}	Equivalent series resistance at 120 Hz
Z	Impedance at 10 kHz
I _R	Rated alternating current (rms) at 120 Hz, upper category temperature

Note

- Unless otherwise specified, all electrical values apply at
T_{amb} = 20 °C, P = 80 to 120 kPa, RH = 45 to 75%.

ORDERING EXAMPLE

The 12th place of ordering code refers to the length of the snap-in pins

EYN07 ...02 0 = snap-in pin 6mm
EYN07 ...42 4 = snap-in pin 4mm

The 13th place of ordering code refers to the kind of insulation

EYN07 ...02 2 = fully insulated (standard)

On special request only:

EYN07 ...01 1 = sleeve insulation

The 14th place (□), not indicated in the following table, is an inter-company code and is not relevant to your order.

EYN07LV44F42 = EYN 4700 μF/35 V 22mm x 30mm, snap-in pin 4mm, fully insulated

ELECTRICAL DATA AND ORDERING INFORMATION								
U _R (V)	C _R 120 Hz (μF)	NOMINAL CASE SIZE D x L (mm)	Tan δ 120 Hz MAX.	R _{ESR} 120 Hz max. (Ω)	Z 10 kHz MAX. (Ω)	I _R 120 Hz 85 °C (A)	WEIGHT [G]	CATALOG NUMBER
6.3	15000	22 x 25	0.59	0.055	0.045	2.9	14	EYN07LU515B02□
	18000	22 x 30	0.62	0.050	0.040	3.3	16	EYN07LV518B02□
	18000	25 x 25	0.62	0.050	0.040	3.4	18	EYN07AU518B02□
	22000	22 x 35	0.66	0.040	0.035	3.7	19	EYN07LA522B02□
	22000	25 x 25	0.66	0.040	0.035	3.6	18	EYN07AU522B02□
	27000	22 x 40	0.71	0.035	0.030	4.1	22	EYN07LB527B02□
	27000	25 x 30	0.71	0.035	0.030	4.1	21	EYN07AV527B02□
	27000	30 x 25	0.71	0.035	0.030	4.2	25	EYN07BU527B02□
	33000	22 x 45	0.77	0.035	0.030	4.6	24	EYN07LC533B02□
	33000	25 x 35	0.77	0.035	0.030	4.5	25	EYN07AA533B02□
	33000	30 x 30	0.77	0.035	0.030	4.6	30	EYN07BV533B02□
	39000	22 x 50	0.83	0.030	<0.030	5.0	27	EYN07LD539B02□
	39000	25 x 40	0.83	0.030	<0.030	4.9	28	EYN07AB539B02□
	39000	30 x 30	0.83	0.030	<0.030	4.8	30	EYN07BV539B02□
	39000	35 x 25	0.83	0.030	<0.030	4.9	34	EYN07CU539B02□
	47000	25 x 45	0.91	0.030	<0.030	5.4	31	EYN07AC547B02□
	47000	30 x 35	0.91	0.030	<0.030	5.3	35	EYN07BA547B02□
	47000	35 x 30	0.91	0.030	<0.030	5.4	41	EYN07CV547B02□
	56000	25 x 50	1.00	<0.030	<0.030	5.8	35	EYN07AD556B02□
	56000	30 x 40	1.00	<0.030	<0.030	5.8	40	EYN07BB556B02□
56000	35 x 30	1.00	<0.030	<0.030	5.6	41	EYN07CV556B02□	
68000	30 x 45	1.12	<0.030	<0.030	6.2	45	EYN07BC568B02□	
68000	35 x 35	1.12	<0.030	<0.030	6.1	48	EYN07CA568B02□	
100000	35 x 40	1.44	<0.030	<0.030	7.1	62	EYN07CC610B02□	
100000	40 x 40	1.44	<0.030	<0.030	7.2	72	EYN07DB610B02□	
10	12000	22 x 25	0.51	0.060	0.050	2.8	14	EYN07LU512C02□
	15000	22 x 30	0.54	0.050	0.040	3.2	16	EYN07LV515C02□
	15000	25 x 25	0.54	0.050	0.040	2.9	18	EYN07AU515C02□
	18000	22 x 35	0.57	0.045	0.035	3.6	19	EYN07LA518C02□
	18000	25 x 25	0.57	0.045	0.035	3.5	18	EYN07AU518C02□
	22000	22 x 40	0.61	0.040	0.030	4.1	22	EYN07LB522C02□
	22000	25 x 30	0.61	0.040	0.030	4.0	21	EYN07AV522C02□
	22000	30 x 25	0.61	0.040	0.030	4.1	25	EYN07BU522C02□
	27000	22 x 45	0.66	0.035	0.030	4.5	24	EYN07LC527C02□
	27000	25 x 35	0.66	0.035	0.030	4.5	25	EYN07AA527C02□
	27000	30 x 30	0.66	0.035	0.030	4.6	30	EYN07BV527C02□
	33000	22 x 50	0.72	0.030	<0.030	4.9	27	EYN07LD533C02□
	33000	25 x 40	0.72	0.030	<0.030	4.9	28	EYN07AB533C02□
	33000	30 x 30	0.72	0.030	<0.030	4.8	30	EYN07BV533C02□

ELECTRICAL DATA AND ORDERING INFORMATION								
U _R (V)	C _R 120 Hz (μF)	NOMINAL CASE SIZE D x L (mm)	Tan δ 120 Hz MAX.	R _{ESR} 120 Hz max. (Ω)	Z 10 kHz MAX. (Ω)	I _R 120 Hz 85 °C (A)	WEIGHT [G]	CATALOG NUMBER
10	33000	35 x 25	0.72	0.030	<0.030	4.9	34	EYN07CU533C02□
	39000	25 x 45	0.78	0.030	<0.030	5.4	31	EYN07AC539C02□
	39000	30 x 25	0.78	0.030	<0.030	5.3	25	EYN07BU539C02□
	39000	35 x 30	0.78	0.030	<0.030	5.4	41	EYN07CV539C02□
	47000	25 x 50	0.86	<0.030	<0.030	5.8	35	EYN07AD547C02□
	47000	30 x 40	0.86	<0.030	<0.030	5.8	40	EYN07BB547C02□
	47000	35 x 30	0.86	<0.030	<0.030	5.6	41	EYN07CV547C02□
	56000	30 x 45	0.95	<0.030	<0.030	6.2	45	EYN07BC556C02□
	56000	35 x 35	0.95	<0.030	<0.030	6.1	48	EYN07CA556C02□
	68000	35 x 40	1.07	<0.030	<0.030	6.6	55	EYN07CB568C02□
100000	40 x 50	1.39	<0.030	<0.030	7.9	89	EYN07DD610C02□	
16	10000	22 x 25	0.44	0.060	0.050	2.8	14	EYN07LU510C02□
	12000	22 x 30	0.46	0.055	0.040	3.0	16	EYN07LV512D02□
	12000	25 x 25	0.46	0.055	0.040	3.3	18	EYN07AU512D02□
	15000	22 x 35	0.49	0.045	0.035	3.6	19	EYN07LA515D02□
	15000	25 x 30	0.49	0.045	0.035	3.8	21	EYN07AV515D02□
	15000	30 x 25	0.49	0.045	0.035	3.9	25	EYN07BU515D02□
	18000	22 x 40	0.52	0.040	0.030	4.1	22	EYN07LB518D02□
	18000	25 x 35	0.52	0.040	0.030	4.2	25	EYN07AA518D02□
	18000	30 x 30	0.52	0.040	0.030	4.3	30	EYN07BV518D02□
	22000	22 x 50	0.56	0.035	0.030	4.7	27	EYN07LD522D02□
	22000	25 x 40	0.56	0.035	0.030	4.7	28	EYN07AB522D02□
	22000	30 x 30	0.56	0.035	0.030	4.6	30	EYN07BV522D02□
	27000	25 x 45	0.61	0.030	<0.030	5.2	31	EYN07AC527D02□
	27000	30 x 35	0.61	0.030	<0.030	5.1	35	EYN07BA527D02□
	27000	35 x 25	0.61	0.030	<0.030	4.9	34	EYN07CU527D02□
	33000	30 x 40	0.67	0.030	<0.030	5.6	40	EYN07BB533D02□
	33000	35 x 30	0.67	0.030	<0.030	5.4	41	EYN07CV533D02□
	39000	30 x 45	0.73	<0.030	<0.030	6.0	45	EYN07BC539D02□
	39000	35 x 35	0.73	<0.030	<0.030	5.9	48	EYN07CA539D02□
	47000	30 x 50	0.81	<0.030	<0.030	6.5	50	EYN07BD547D02□
	47000	35 x 40	0.81	<0.030	<0.030	6.4	55	EYN07CB547D02□
	56000	35 x 45	0.90	<0.030	<0.030	6.9	62	EYN07CC556D02□
	56000	40 x 40	0.90	<0.030	<0.030	7.0	72	EYN07DB556D02□
	68000	35 x 50	1.02	<0.030	<0.030	7.3	68	EYN07CD568D02□
68000	40 x 50	1.02	<0.030	<0.030	7.8	89	EYN07DD568D02□	
100000	40 x 60	1.34	<0.030	<0.030	8.7	107	EYN07DF610D02□	
25	5600	22 x 25	0.37	0.090	0.070	2.3	14	EYN07LU456E02□
	6800	22 x 30	0.38	0.075	0.060	2.6	16	EYN07LV468E02□
	6800	25 x 25	0.38	0.075	0.060	2.7	18	EYN07AU468E02□
	8200	22 x 35	0.39	0.065	0.050	2.9	19	EYN07LA482E02□
	8200	25 x 30	0.39	0.065	0.050	3.0	21	EYN07AV482E02□
	10000	22 x 40	0.41	0.055	0.045	3.4	22	EYN07LB510E02□
	10000	25 x 30	0.41	0.055	0.045	3.3	21	EYN07AV510E02□
	10000	30 x 25	0.41	0.055	0.045	3.4	25	EYN07BU510E02□
	12000	22 x 45	0.42	0.050	0.035	3.7	24	EYN07LC512E02□
	12000	25 x 35	0.42	0.050	0.035	3.7	25	EYN07AA512E02□
	12000	30 x 30	0.42	0.050	0.035	3.8	30	EYN07BV512E02□
	15000	22 x 50	0.44	0.040	0.030	4.2	27	EYN07LD515E02□
	15000	25 x 40	0.44	0.040	0.030	4.2	28	EYN07AB515E02□
	15000	30 x 35	0.44	0.040	0.030	4.3	35	EYN07BA515E02□
	18000	25 x 45	0.47	0.035	0.030	4.6	31	EYN07AC518E02□
	18000	30 x 35	0.47	0.035	0.030	4.6	35	EYN07BA518E02□
	18000	35 x 30	0.47	0.035	0.030	4.7	41	EYN07CV518E02□
	22000	30 x 45	0.50	0.030	<0.030	5.3	45	EYN07BC522E02□
	22000	35 x 35	0.50	0.030	<0.030	5.2	48	EYN07CA522E02□
	27000	30 x 50	0.54	0.030	<0.030	5.8	50	EYN07BD527E02□
	27000	35 x 40	0.54	0.030	<0.030	5.7	55	EYN07CB527E02□
	33000	35 x 45	0.58	<0.030	<0.030	6.2	62	EYN07CC533E02□
	33000	40 x 40	0.58	<0.030	<0.030	6.4	72	EYN07DB533E02□



Aluminum Capacitors
Standard - 85 °C Snap-in

Vishay Roederstein

ELECTRICAL DATA AND ORDERING INFORMATION								
U _R (V)	C _R 120 Hz (μF)	NOMINAL CASE SIZE D x L (mm)	Tan δ 120 Hz MAX.	R _{ESR} 120 Hz max. (Ω)	Z 10 kHz MAX. (Ω)	I _R 120 Hz 85 °C (A)	WEIGHT [G]	CATALOG NUMBER
35	4700	22 x 30	0.29	0.085	0.060	2.6	16	EYN07LV447F02□
	4700	25 x 25	0.29	0.085	0.060	2.5	18	EYN07AU447F02□
	5600	22 x 35	0.30	0.075	0.055	2.8	19	EYN07LA456F02□
	5600	25 x 30	0.30	0.075	0.055	2.9	21	EYN07AV456F02□
	6800	22 x 40	0.30	0.060	0.045	3.2	22	EYN07LB468F02□
	6800	25 x 30	0.30	0.060	0.045	3.1	21	EYN07AV468F02□
	6800	30 x 25	0.30	0.060	0.045	3.2	25	EYN07BU468F02□
	8200	22 x 45	0.31	0.055	0.040	3.5	24	EYN07LC482F02□
	8200	25 x 35	0.31	0.055	0.040	3.5	25	EYN07AA482F02□
	8200	30 x 30	0.31	0.055	0.040	3.6	30	EYN07BV482F02□
	10000	22 x 50	0.32	0.045	0.035	4.0	27	EYN07LD510F02□
	10000	25 x 40	0.32	0.045	0.035	4.0	28	EYN07AB510F02□
	10000	30 x 30	0.32	0.045	0.035	3.9	30	EYN07BV510F02□
	12000	25 x 45	0.34	0.040	0.030	4.4	31	EYN07AC512F02□
	12000	30 x 35	0.34	0.040	0.030	4.3	35	EYN07BA512F02□
	12000	35 x 30	0.34	0.040	0.030	4.5	41	EYN07CV512F02□
	15000	30 x 40	0.36	0.035	<0.030	4.9	40	EYN07BB515F02□
	15000	35 x 35	0.36	0.035	<0.030	5.0	48	EYN07CA515F02□
	18000	30 x 45	0.38	0.030	<0.030	5.3	45	EYN07BC518F02□
	18000	35 x 40	0.38	0.030	<0.030	5.5	55	EYN07CB518F02□
22000	35 x 45	0.40	<0.030	<0.030	6.0	62	EYN07CC522F02□	
22000	40 x 40	0.40	<0.030	<0.030	6.1	72	EYN07DB522F02□	
27000	40 x 50	0.43	<0.030	<0.030	6.9	89	EYN07DD527F02□	
33000	40 x 50	0.47	<0.030	<0.030	7.2	89	EYN07DD533F02□	
50	3300	22 x 30	0.23	0.095	0.075	2.5	16	EYN07LV433H02□
	3300	25 x 25	0.23	0.095	0.075	2.6	18	EYN07AU433H02□
	4700	22 x 40	0.24	0.070	0.055	3.3	22	EYN07LB447H02□
	4700	25 x 35	0.24	0.070	0.055	3.4	25	EYN07AA447H02□
	4700	30 x 25	0.24	0.070	0.055	3.3	25	EYN07BU447H02□
	4700	35 x 25	0.24	0.070	0.055	3.6	34	EYN07CU447H02□
	5600	22 x 45	0.24	0.060	0.045	3.6	24	EYN07LC456H02□
	5600	25 x 40	0.24	0.060	0.045	3.8	28	EYN07AB456H02□
	5600	30 x 30	0.24	0.060	0.045	3.7	30	EYN07BV456H02□
	5600	35 x 25	0.24	0.060	0.045	3.8	34	EYN07CU456H02□
	6800	22 x 50	0.25	0.050	0.040	4.1	27	EYN07LD468H02□
	6800	25 x 40	0.25	0.050	0.040	4.0	28	EYN07AB468H02□
	6800	30 x 35	0.25	0.050	0.040	4.2	35	EYN07DF527H02□
	6800	35 x 30	0.25	0.050	0.040	4.3	41	EYN07CV468H02□
	8200	25 x 50	0.26	0.045	0.035	4.6	35	EYN07AD482H02□
	8200	30 x 40	0.26	0.045	0.035	4.6	40	EYN07BB482H02□
	8200	35 x 30	0.26	0.045	0.035	4.5	41	EYN07CV482H02□
	10000	30 x 45	0.26	0.035	0.030	5.2	45	EYN07BC510H02□
	10000	35 x 35	0.26	0.035	0.030	5.1	48	EYN07CA510H02□
	12000	30 x 50	0.27	0.035	<0.030	5.6	50	EYN07BD512H02□
	12000	35 x 40	0.27	0.035	<0.030	5.6	55	EYN07CB512H02□
	15000	35 x 45	0.28	0.030	<0.030	6.1	62	EYN07CC515H02□
	18000	35 x 50	0.30	<0.030	<0.030	6.6	68	EYN07CD518H02□
	18000	40 x 40	0.30	<0.030	<0.030	6.5	72	EYN07DB518H02□
	22000	40 x 50	0.31	<0.030	<0.030	7.3	89	EYN07DD522H02□
	27000	40 x 60	0.34	<0.030	<0.030	8.0	107	EYN07DF527H02□

ELECTRICAL DATA AND ORDERING INFORMATION

U_R (V)	C_R 120 Hz (μ F)	NOMINAL CASE SIZE D x L (mm)	$\tan \delta$ 120 Hz MAX.	R_{ESR} 120 Hz max. (Ω)	Z 10 kHz MAX. (Ω)	I_R 120 Hz 85 °C (A)	WEIGHT [G]	CATALOG NUMBER
63	1800	22 x 25	0.20	0.150	0.105	1.9	14	EYN07LU418J02□
	2200	22 x 30	0.20	0.125	0.090	2.1	16	EYN07LV422J02□
	2200	25 x 25	0.20	0.125	0.090	2.2	18	EYN07AU422J02□
	2700	22 x 35	0.21	0.105	0.075	2.5	19	EYN07LA427J02□
	2700	25 x 30	0.21	0.105	0.075	2.6	21	EYN07AV427J02□
	3300	22 x 35	0.21	0.085	0.060	2.7	19	EYN07LA433J02□
	3300	25 x 30	0.21	0.085	0.060	2.8	21	EYN07AV433J02□
	3300	30 x 25	0.21	0.085	0.060	2.8	25	EYN07BU433J02□
	3900	22 x 40	0.21	0.075	0.055	3.1	22	EYN07LB439J02□
	3900	25 x 35	0.21	0.075	0.055	3.2	25	EYN07AA439J02□
	3900	30 x 30	0.21	0.075	0.055	3.3	30	EYN07BV439J02□
	4700	22 x 50	0.22	0.065	0.045	3.6	27	EYN07LD447J02□
	4700	25 x 40	0.22	0.065	0.045	3.6	28	EYN07AB447J02□
	4700	30 x 35	0.22	0.065	0.045	3.5	35	EYN07BA447J02□
	4700	35 x 30	0.22	0.065	0.045	3.6	41	EYN07CV447J02□
	5600	25 x 45	0.22	0.055	0.040	4.0	31	EYN07AC456J02□
	5600	30 x 35	0.22	0.055	0.040	3.9	35	EYN07BA456J02□
	5600	35 x 30	0.22	0.055	0.040	4.0	41	EYN07CV456J02□
	6800	25 x 50	0.23	0.045	0.035	4.4	35	EYN07AD468J02□
	6800	30 x 40	0.23	0.045	0.035	4.4	40	EYN07BB468J02□
	6800	35 x 30	0.23	0.045	0.035	4.3	41	EYN07CV468J02□
	8200	30 x 45	0.24	0.040	0.030	4.8	45	EYN07BC482J02□
	8200	35 x 35	0.24	0.040	0.030	4.7	48	EYN07CA482J02□
	10000	30 x 50	0.25	0.035	<0.030	5.4	50	EYN07BD510J02□
10000	35 x 40	0.25	0.035	<0.030	5.3	55	EYN07CB510J02□	
12000	35 x 45	0.26	0.030	<0.030	5.8	62	EYN07CC512J02□	
12000	40 x 40	0.26	0.030	<0.030	5.9	72	EYN07DB512J02□	
100	1200	22 x 30	0.15	0.165	0.115	2.0	16	EYN07LV412L02□
	1200	25 x 25	0.15	0.165	0.165	2.1	18	EYN07AU412L02□
	1500	22 x 35	0.15	0.135	0.090	2.4	19	EYN07LA415L02□
	1500	25 x 30	0.15	0.135	0.090	2.5	21	EYN07AV415L02□
	1500	30 x 25	0.15	0.135	0.090	2.6	25	EYN07BU415L02□
	1800	22 x 40	0.15	0.115	0.080	2.8	22	EYN07LB418L02□
	1800	25 x 35	0.15	0.115	0.080	2.9	25	EYN07AA418L02□
	1800	30 x 30	0.15	0.115	0.080	3.0	30	EYN07BV418L02□
	2200	22 x 45	0.15	0.095	0.065	3.0	24	EYN07LC422L02□
	2200	25 x 40	0.15	0.095	0.065	3.2	28	EYN07AB422L02□
	2200	30 x 30	0.15	0.095	0.065	3.1	30	EYN07BV422L02□
	2700	25 x 45	0.16	0.080	0.055	3.7	31	EYN07AC427L02□
	2700	30 x 35	0.16	0.080	0.055	3.6	35	EYN07BA427L02□
	2700	35 x 30	0.16	0.080	0.055	3.7	41	EYN07CV427L02□
	3300	25 x 50	0.16	0.065	0.045	4.0	35	EYN07AD433L02□
	3300	25 x 40	0.16	0.065	0.045	4.0	40	EYN07BB433L02□
	3300	35 x 35	0.16	0.065	0.045	4.1	48	EYN07CA433L02□
	3900	30 x 45	0.16	0.060	0.040	4.6	45	EYN07BC439L02□
	3900	35 x 35	0.16	0.060	0.040	4.5	48	EYN07CA439L02□
	4700	30 x 50	0.17	0.050	0.035	5.0	50	EYN07BD447L02□
	4700	35 x 40	0.17	0.050	0.035	4.9	55	EYN07CB447L02□
	5600	35 x 45	0.17	0.045	0.030	5.4	62	EYN07CC456L02□
	5600	40 x 40	0.17	0.045	0.030	5.5	72	EYN07DB456L02□
	6800	40 x 50	0.18	0.040	<0.030	6.3	89	EYN07DD468L02□
	8200	40 x 50	0.19	0.035	<0.030	6.5	89	EYN07DD482L02□



Aluminum Capacitors
Standard - 85 °C Snap-in

Vishay Roederstein

ELECTRICAL DATA AND ORDERING INFORMATION								
U _R (V)	C _R 120 Hz (μF)	NOMINAL CASE SIZE D x L (mm)	Tan δ 120 Hz MAX.	R _{ESR} 120 Hz max. (Ω)	Z 10 kHz MAX. (Ω)	I _R 120 Hz 85 °C (A)	WEIGHT [G]	CATALOG NUMBER
160	220	22 x 20	0.14	0.825	0.595	0.86	11	EYN07LW322M02□
	270	22 x 25	0.14	0.680	0.490	1.0	14	EYN07LU327M02□
	270	25 x 20	0.14	0.680	0.490	1.1	14	EYN07AW327M02□
	330	22 x 25	0.14	0.565	0.405	1.1	14	EYN07LU333M02□
	330	25 x 20	0.14	0.565	0.405	1.2	14	EYN07AW333M02□
	390	22 x 25	0.14	0.485	0.350	1.2	14	EYN07LU339M02□
	390	25 x 25	0.14	0.485	0.350	1.4	18	EYN07AU339M02□
	390	30 x 20	0.14	0.485	0.350	1.4	20	EYN07BW339M02□
	470	22 x 30	0.14	0.410	0.295	1.4	16	EYN07LV347M02□
	470	25 x 25	0.14	0.410	0.295	1.5	18	EYN07AU347M02□
	470	30 x 20	0.14	0.410	0.295	1.5	20	EYN07BW347M02□
	560	22 x 35	0.15	0.350	0.250	1.7	19	EYN07LA356M02□
	560	25 x 30	0.15	0.350	0.250	1.7	21	EYN07AV356M02□
	560	30 x 25	0.15	0.350	0.250	1.8	25	EYN07BU356M02□
	560	35 x 20	0.15	0.350	0.250	1.8	27	EYN07CW356M02□
	680	22 x 40	0.15	0.295	0.215	1.9	22	EYN07LB368M02□
	680	25 x 30	0.15	0.295	0.215	1.9	21	EYN07AV368M02□
	680	30 x 25	0.15	0.295	0.215	1.9	25	EYN07BU368M02□
	680	35 x 20	0.15	0.295	0.215	2.0	27	EYN07CW368M02□
	820	22 x 45	0.15	0.250	0.180	2.2	24	EYN07LC382M02□
	820	25 x 35	0.15	0.250	0.180	2.2	25	EYN07AA382M02□
	820	30 x 30	0.15	0.250	0.180	2.3	30	EYN07BV382M02□
	820	35 x 25	0.15	0.250	0.180	2.3	34	EYN07CU382M02□
	1000	22 x 50	0.16	0.215	0.155	2.6	27	EYN07LD410M02□
	1000	25 x 40	0.16	0.215	0.155	2.6	28	EYN07AB410M02□
	1000	30 x 30	0.16	0.215	0.155	2.5	30	EYN07BV410M02□
	1000	35 x 25	0.16	0.215	0.155	2.6	34	EYN07CU410M02□
	1200	25 x 45	0.16	0.185	0.135	2.7	31	EYN07AC412M02□
	1200	30 x 35	0.16	0.185	0.135	2.7	35	EYN07BA412M02□
	1200	35 x 30	0.16	0.185	0.135	2.8	41	EYN07CV412M02□
	1500	30 x 40	0.17	0.155	0.115	3.2	40	EYN07BB415M02□
	1500	35 x 35	0.17	0.155	0.115	3.3	48	EYN07CA415M02□
1800	35 x 40	0.18	0.135	0.100	3.7	55	EYN07CB418M02□	
1800	40 x 40	0.18	0.135	0.100	4.0	72	EYN07DB418M02□	
200	180	22 x 20	0.13	0.925	0.695	0.77	11	EYN07LW318S02□
	220	22 x 25	0.13	0.765	0.575	0.93	14	EYN07LU322S02□
	220	25 x 20	0.13	0.765	0.575	0.94	14	EYN07AW322S02□
	270	22 x 25	0.13	0.630	0.475	1.0	14	EYN07LU327S02□
	270	25 x 25	0.13	0.630	0.475	1.1	18	EYN07AU327S02□
	270	30 x 20	0.13	0.630	0.475	1.1	20	EYN07BW327S02□
	330	22 x 30	0.13	0.525	0.395	1.2	16	EYN07LV333S02□
	330	25 x 25	0.13	0.525	0.395	1.2	18	EYN07AU333S02□
	330	30 x 20	0.13	0.525	0.395	1.3	20	EYN07BW333S02□
	390	22 x 30	0.13	0.450	0.335	1.3	16	EYN07LV339S02□
	390	25 x 25	0.13	0.450	0.335	1.4	18	EYN07AU339S02□
	390	30 x 25	0.13	0.450	0.335	1.5	25	EYN07BU339S02□
	390	35 x 20	0.13	0.450	0.335	1.5	27	EYN07CW339S02□
	470	22 x 35	0.13	0.380	0.285	1.5	19	EYN07LA347S02□
	470	25 x 30	0.13	0.380	0.285	1.6	21	EYN07AV347S02□

ELECTRICAL DATA AND ORDERING INFORMATION								
U _R (V)	C _R 120 Hz (μF)	NOMINAL CASE SIZE D x L (mm)	Tan δ 120 Hz MAX.	R _{ESR} 120 Hz max. (Ω)	Z 10 kHz MAX. (Ω)	I _R 120 Hz 85 °C (A)	WEIGHT [G]	CATALOG NUMBER
200	470	30 x 25	0.13	0.380	0.285	1.6	25	EYN07BU347S02□
	470	35 x 20	0.13	0.380	0.285	1.6	27	EYN07CW347S02□
	560	22 x 40	0.14	0.325	0.245	1.8	22	EYN07LB356S02□
	560	25 x 35	0.14	0.325	0.245	1.8	25	EYN07AA356S02□
	560	30 x 25	0.14	0.325	0.245	1.8	25	EYN07BU356S02□
	560	35 x 25	0.14	0.325	0.245	1.9	34	EYN07CU356S02□
	680	22 x 45	0.14	0.275	0.205	2.0	24	EYN07LC368S02□
	680	25 x 40	0.14	0.275	0.205	2.1	28	EYN07AB368S02□
	680	30 x 30	0.14	0.275	0.205	2.1	30	EYN07BV368S02□
	680	35 x 25	0.14	0.275	0.205	2.1	34	EYN07CU368S02□
	820	22 x 50	0.14	0.235	0.175	2.3	27	EYN07LD382S02□
	820	25 x 45	0.14	0.235	0.175	2.4	31	EYN07AC382S02□
	820	30 x 35	0.14	0.235	0.175	2.4	35	EYN07BA382S02□
	820	35 x 30	0.14	0.235	0.175	2.4	41	EYN07CV382S02□
	1000	30 x 40	0.15	0.200	0.150	2.8	40	EYN07BB410S02□
	1000	35 x 30	0.15	0.200	0.150	2.7	41	EYN07CV410S02□
	1200	30 x 45	0.15	0.175	0.130	3.0	45	EYN07BC410S02□
	1200	35 x 35	0.15	0.175	0.130	2.9	48	EYN07CA412S02□
1500	30 x 50	0.16	0.145	0.110	3.5	50	EYN07BD415S02□	
1500	35 x 40	0.16	0.145	0.110	3.4	55	EYN07CB415S02□	
1800	35 x 45	0.17	0.130	0.100	3.9	62	EYN07CC418S02□	
1800	40 x 40	0.17	0.130	0.100	4.0	72	EYN07DB418S02□	
250	150	22 x 25	0.12	1.100	0.760	0.77	14	EYN07LU315N02□
	150	25 x 20	0.12	1.100	0.760	0.78	14	EYN07AW315N02□
	180	22 x 25	0.13	0.925	0.640	0.77	14	EYN07LU318N02□
	180	25 x 20	0.13	0.925	0.640	0.86	14	EYN07AW318N02□
	220	22 x 25	0.13	0.765	0.530	0.93	14	EYN07LU322N02□
	220	25 x 25	0.13	0.765	0.530	1.0	18	EYN07AU322N02□
	220	30 x 20	0.13	0.765	0.530	1.0	20	EYN07BW322N02□
	270	22 x 30	0.13	0.630	0.435	1.1	16	EYN07LV327N02□
	270	25 x 25	0.13	0.630	0.435	1.1	18	EYN07AU327N02□
	270	30 x 20	0.13	0.630	0.435	1.1	20	EYN07BW327N02□
	330	22 x 35	0.13	0.525	0.360	1.3	19	EYN07LA333N02□
	330	25 x 30	0.13	0.525	0.360	1.3	21	EYN07AV333N02□
	330	30 x 25	0.13	0.525	0.360	1.4	25	EYN07BU333N02□
	330	35 x 20	0.13	0.525	0.360	1.4	27	EYN07CW333N02□
	390	22 x 40	0.13	0.450	0.310	1.5	22	EYN07LB339N02□
	390	25 x 30	0.13	0.450	0.310	1.4	21	EYN07AV339N02□
	390	30 x 25	0.13	0.450	0.310	1.5	25	EYN07BU339N02□
	390	35 x 20	0.13	0.450	0.310	1.5	27	EYN07CW339N02□
	470	22 x 45	0.13	0.380	0.265	1.7	24	EYN07LC347N02□
	470	25 x 35	0.13	0.380	0.265	1.7	25	EYN07AA347N02□
	470	30 x 30	0.13	0.380	0.265	1.7	30	EYN07BV347N02□
	470	35 x 25	0.13	0.380	0.265	1.8	34	EYN07CU347N02□
	560	22 x 50	0.14	0.325	0.225	1.9	27	EYN07LD356N02□
	560	25 x 40	0.14	0.325	0.225	1.9	28	EYN07AB356N02□
	560	30 x 30	0.14	0.325	0.225	1.9	30	EYN07BV356N02□
	560	35 x 25	0.14	0.325	0.225	1.9	34	EYN07CU356N02□
	680	25 x 45	0.14	0.275	0.190	2.2	31	EYN07AC368N02□
	680	30 x 35	0.14	0.275	0.190	2.2	35	EYN07BA368N02□
680	35 x 30	0.14	0.275	0.190	2.2	41	EYN07CV368N02□	
820	30 x 40	0.14	0.235	0.165	2.5	40	EYN07BB382N02□	



Aluminum Capacitors
Standard - 85 °C Snap-in

Vishay Roederstein

ELECTRICAL DATA AND ORDERING INFORMATION								
U _R (V)	C _R 120 Hz (μF)	NOMINAL CASE SIZE D x L (mm)	Tan δ 120 Hz MAX.	R _{ESR} 120 Hz max. (Ω)	Z 10 kHz MAX. (Ω)	I _R 120 Hz 85 °C (A)	WEIGHT [G]	CATALOG NUMBER
250	820	35 x 35	0.14	0.235	0.165	2.6	48	EYN07CA382N02□
	1000	30 x 45	0.15	0.200	0.140	2.9	45	EYN07BC410N02□
	1000	35 x 40	0.15	0.200	0.140	3.0	55	EYN07CB410N02□
	1200	35 x 45	0.15	0.175	0.120	3.2	62	EYN07CC412N02□
	1200	40 x 40	0.15	0.175	0.120	3.2	72	EYN07DB412N02□
	1500	35 x 50	0.16	0.145	0.100	3.7	68	EYN07CD415N02□
	1500	40 x 50	0.16	0.145	0.100	3.9	89	EYN07DD415N02□
	1800	40 x 60	0.17	0.130	0.090	4.6	107	EYN07DF418N02□
350	82	22 x 20	0.12	1.980	1.370	0.53	11	EYN07LW282O02□
	100	22 x 25	0.12	1.635	1.125	0.62	14	EYN07LU310O02□
	100	25 x 20	0.12	1.635	1.125	0.64	14	EYN07AW310O02□
	120	22 x 30	0.12	1.365	0.945	0.73	16	EYN07LV312O02□
	120	25 x 25	0.12	1.365	0.945	0.75	18	EYN07AU312O02□
	120	30 x 20	0.12	1.365	0.945	0.77	20	EYN07BW312O02□
	150	22 x 35	0.12	1.100	0.760	0.86	19	EYN07LA315O02□
	150	25 x 30	0.12	1.100	0.760	0.89	21	EYN07AV315O02□
	150	30 x 20	0.12	1.100	0.760	0.86	20	EYN07BW315O02□
	180	22 x 40	0.13	0.925	0.640	0.99	22	EYN07LB318O02□
	180	25 x 35	0.13	0.925	0.640	1.0	25	EYN07AA318O02□
	180	30 x 25	0.13	0.925	0.640	1.0	25	EYN07BU318O02□
	180	35 x 20	0.13	0.925	0.640	1.0	27	EYN07CW318O02□
	220	22 x 45	0.13	0.765	0.530	1.1	24	EYN07LC322O02□
	220	25 x 35	0.13	0.765	0.530	1.1	25	EYN07AA322O02□
	220	30 x 30	0.13	0.765	0.530	1.2	30	EYN07BV322O02□
	220	35 x 25	0.13	0.765	0.530	1.2	34	EYN07CU322O02□
	270	25 x 45	0.13	0.630	0.435	1.4	31	EYN07AC327O02□
	270	30 x 35	0.13	0.630	0.435	1.4	35	EYN07BA327O02□
	270	35 x 25	0.13	0.630	0.435	1.4	34	EYN07CU327O02□
	330	25 x 50	0.13	0.525	0.360	1.6	35	EYN07AD333O02□
	330	30 x 40	0.13	0.525	0.360	1.6	40	EYN07BB333O02□
	330	35 x 30	0.13	0.525	0.360	1.6	41	EYN07CV333O02□
	390	30 x 45	0.13	0.450	0.310	1.8	45	EYN07BC339O02□
	390	35 x 35	0.13	0.450	0.310	1.8	48	EYN07CA339O02□
	470	30 x 50	0.13	0.380	0.265	2.1	50	EYN07BD347O02□
	470	35 x 40	0.13	0.380	0.265	2.0	55	EYN07CB347O02□
	560	35 x 45	0.14	0.325	0.225	2.3	62	EYN07CC356O02□
680	35 x 50	0.14	0.275	0.190	2.7	68	EYN07CD368O02□	
680	40 x 40	0.14	0.275	0.190	2.6	72	EYN07DB368O02□	
820	40 x 50	0.14	0.235	0.165	3.1	89	EYN07DD382O02□	
400	68	22 x 20	0.12	2.380	1.620	0.48	11	EYN07LW268X02□
	82	22 x 25	0.12	1.980	1.350	0.56	14	EYN07LU282X02□
	82	25 x 20	0.12	1.980	1.350	0.58	14	EYN07AW282X02□
	100	22 x 30	0.12	1.635	1.110	0.66	16	EYN07LV310X02□
	100	25 x 25	0.12	1.635	1.110	0.69	18	EYN07AU310X02□
	100	30 x 20	0.12	1.635	1.110	0.70	20	EYN07BW310X02□
	120	22 x 30	0.12	1.365	0.930	0.73	16	EYN07LV312X02□
	120	25 x 25	0.12	1.365	0.930	0.75	18	EYN07AU312X02□
	120	30 x 20	0.12	1.365	0.930	0.77	20	EYN07BW312X02□
	150	22 x 35	0.12	1.100	0.750	0.86	19	EYN07LA315X02□
	150	25 x 30	0.12	1.100	0.750	0.89	21	EYN07AV315X02□

ELECTRICAL DATA AND ORDERING INFORMATION

U_R (V)	C_R 120 Hz (μ F)	NOMINAL CASE SIZE D x L (mm)	$\tan \delta$ 120 Hz MAX.	R_{ESR} 120 Hz max. (Ω)	Z 10 kHz MAX. (Ω)	I_R 120 Hz 85 °c (A)	WEIGHT [G]	CATALOG NUMBER
400	150	30 x 25	0.12	1.100	0.750	0.92	25	EYN07BU315X02□
	150	35 x 20	0.12	1.100	0.750	0.93	27	EYN07CW315X02□
	180	22 x 40	0.13	0.925	0.630	0.99	22	EYN07LB318X02□
	180	25 x 35	0.13	0.925	0.630	1.0	25	EYN07AA318X02□
	180	30 x 25	0.13	0.925	0.630	1.0	25	EYN07BU318X02□
	180	35 x 25	0.13	0.925	0.630	1.1	34	EYN07CU318X02□
	220	22 x 45	0.13	0.765	0.520	1.1	24	EYN07LC322X02□
	220	25 x 40	0.13	0.765	0.520	1.2	28	EYN07AB322X02□
	220	30 x 30	0.13	0.765	0.520	1.2	30	EYN07BV322X02□
	220	35 x 25	0.13	0.765	0.520	1.2	34	EYN07CU322X02□
	270	25 x 45	0.13	0.630	0.430	1.4	31	EYN07AC327X02□
	270	30 x 35	0.13	0.630	0.430	1.4	35	EYN07BA327X02□
	270	35 x 30	0.13	0.630	0.430	1.4	41	EYN07CV327X02□
	330	25 x 50	0.13	0.525	0.355	1.6	35	EYN07AD333X02□
	330	30 x 40	0.13	0.525	0.355	1.6	40	EYN07BB333X02□
	330	35 x 30	0.13	0.525	0.355	1.6	41	EYN07CV333X02□
	390	30 x 45	0.13	0.450	0.305	1.8	45	EYN07BC339X02□
	390	35 x 35	0.13	0.450	0.305	1.8	48	EYN07CA339X02□
	470	30 x 50	0.13	0.380	0.260	2.1	50	EYN07BD347X02□
	470	35 x 40	0.13	0.380	0.260	2.0	55	EYN07CB347X02□
560	35 x 45	0.14	0.325	0.220	2.3	62	EYN07CC356X02□	
560	40 x 40	0.14	0.325	0.220	2.4	72	EYN07DB356X02□	
680	40 x 50	0.14	0.275	0.190	2.8	89	EYN07DD368X02□	
820	40 x 60	0.14	0.235	0.160	3.3	107	EYN07DF382X02□	
450	47	22 x 20	0.15	4.275	2.990	0.36	11	EYN07LW247P02□
	56	22 x 20	0.15	3.595	2.515	0.39	11	EYN07LW256P02□
	68	22 x 25	0.15	2.965	2.075	0.46	14	EYN07LU268P02□
	68	25 x 20	0.15	2.965	2.075	0.47	14	EYN07AW268P02□
	82	22 x 30	0.15	2.465	1.730	0.54	16	EYN07LV282P02□
	82	25 x 25	0.15	2.465	1.730	0.56	18	EYN07AU282P02□
	82	30 x 20	0.15	2.465	1.730	0.57	20	EYN07BW282P02□
	100	22 x 35	0.15	2.030	1.420	0.63	19	EYN07LA310P02□
	100	25 x 30	0.15	2.030	1.420	0.65	21	EYN07AV310P02□
	100	30 x 25	0.15	2.030	1.420	0.67	25	EYN07BU310P02□
	100	35 x 20	0.15	2.030	1.420	0.68	27	EYN07CW310P02□
	120	22 x 40	0.15	1.700	1.190	0.73	22	EYN07LB312P02□
	120	25 x 35	0.15	1.700	1.190	0.76	25	EYN07AA312P02□
	120	30 x 25	0.15	1.700	1.190	0.73	25	EYN07BU312P02□
	120	35 x 20	0.15	1.700	1.190	0.75	27	EYN07CW312P02□
	150	22 x 50	0.15	1.365	0.960	0.89	27	EYN07LD315P02□
	150	25 x 40	0.15	1.365	0.960	0.89	28	EYN07AB315P02□
	150	30 x 30	0.15	1.365	0.960	0.87	30	EYN07BV315P02□
	150	35 x 25	0.15	1.365	0.960	0.89	34	EYN07CU315P02□
	180	25 x 45	0.16	1.145	0.805	1.0	31	EYN07AC318P02□
	180	30 x 35	0.16	1.145	0.805	1.0	35	EYN07BA318P02□
	180	35 x 25	0.16	1.145	0.805	0.98	34	EYN07CU318P02□
	220	25 x 50	0.16	0.945	0.660	1.2	35	EYN07AD322P02□
	220	30 x 40	0.16	0.945	0.660	1.2	40	EYN07BB322P02□
	220	35 x 30	0.16	0.945	0.660	1.1	41	EYN07CV322P02□
	270	30 x 45	0.16	0.780	0.545	1.4	45	EYN07BC327P02□
	270	35 x 35	0.16	0.780	0.545	1.3	48	EYN07CA327P02□
	330	30 x 50	0.16	0.645	0.450	1.6	50	EYN07BD333P02□



ELECTRICAL DATA AND ORDERING INFORMATION								
U _R (V)	C _R 120 Hz (μF)	NOMINAL CASE SIZE D x L (mm)	Tan δ 120 Hz MAX.	R _{ESR} 120 Hz max. (Ω)	Z 10 kHz MAX. (Ω)	I _R 120 Hz 85 °C (A)	WEIGHT [G]	CATALOG NUMBER
450	330	35 x 40	0.16	0.645	0.450	1.5	55	EYN07CB333P02□
	390	35 x 45	0.16	0.550	0.385	1.7	62	EYN07CC339P02□
	470	35 x 50	0.16	0.465	0.325	2.0	68	EYN07CD347P02□
	470	40 x 40	0.16	0.465	0.325	2.0	72	EYN07DB347P02□
	560	40 x 50	0.17	0.395	0.280	2.3	89	EYN07DD356P02□
	680	40 x 60	0.17	0.335	0.235	2.7	107	EYN07DF368P02□
500	68	22 x 30	0.15	2.965	1.930	0.44	16	EYN07LV268Y02□
	82	22 x 35	0.15	2.465	1.605	0.51	19	EYN07LA282Y02□
	82	25 x 30	0.15	2.465	1.605	0.53	21	EYN07AV282Y02□
	100	22 x 40	0.15	2.030	1.320	0.60	22	EYN07LB310Y02□
	100	25 x 35	0.15	2.030	1.320	0.62	25	EYN07AA310Y02□
	120	25 x 40	0.15	1.700	1.105	0.71	28	EYN07AB312Y02□
	150	30 x 35	0.15	1.365	0.890	0.82	35	EYN07BA315Y02□
	180	30 x 40	0.16	1.145	0.745	0.94	40	EYN07BB318Y02□
	220	30 x 45	0.16	0.945	0.615	1.1	45	EYN07BC322Y02□
	270	35 x 45	0.16	0.780	0.505	1.3	62	EYN07CC327Y02□
	330	35 x 50	0.16	0.645	0.420	1.5	68	EYN07CD333Y02□
	470	40 x 50	0.16	0.465	0.305	1.9	89	EYN07DD347Y02□
	560	40 x 60	0.17	0.395	0.260	2.2	107	EYN07DF356Y02□
	680	40 x 60	0.17	0.335	0.220	2.4	107	EYN07DF368Y02□

LOW TEMPERATURE BEHAVIOUR

Table for the calculation of the maximum 10 KHz impedance at low temperatures:

$$Z(10\text{ kHz}) [\Omega] = \frac{\text{Tabular value}}{C_R [\mu\text{F}]}$$

T _a (°C)	RATED VOLTAGE U _R (V)														
	6.3	10	16	25	35	50	63	100	160	200	250	350	400	450	500
25	9000	7200	5400	4050	3150	2700	2250	1710	1960	1820	1680	1870	1870	1870	1870
40	30000	24000	18000	13500	10500	12000	10000	7600	7000	6500	7200	6600	-	-	-

The lower limit of the series resistance and impedance is given by the ohmic part of the contact points and the foil resistance values. Therefore it will not always be possible to achieve calculated values below 0.03 Ω.

LEAKAGE CURRENT

Formula for the calculation of the maximum leakage current I_L for acceptance tests. Testing conditions: U_R, 20 °C, 5 minutes.

$$I_L (300\text{S})/\mu\text{A} \leq 3 \times \sqrt{(C_R/\mu\text{F}) \times (U_R/\text{V})}$$

LIFETIME TABLE $U_R \leq 100\text{ V}$

INTERRELATION BETWEEN ALTERNATING CURRENT, AMBIENT TEMPERATURE AND LIFETIME																
I/I_R (FREQUENCY-DEPENDANT)							LIFETIME MULTIPLIER L (DEPENDING ON I/I_R AND T_A)									
FREQUENCY (HZ)							AMBIENT TEMPERATURE T_A (°C)									
50	100	120	250	500	1000	>2500	40	45	50	55	60	65	70	75	80	85
0.00	0.00	0.00	0.00	0.00	0.00	0.00	66	42	27	17	11	7.6	5.1	3.5	2.4	1.7
0.17	0.19	0.20	0.22	0.23	0.23	0.24	62	40	26	17	11	7.4	5.0	3.4	2.3	1.6
0.34	0.39	0.40	0.43	0.45	0.46	0.47	53	34	22	15	9.9	6.7	4.5	3.1	2.2	1.5
0.51	0.58	0.60	0.65	0.68	0.70	0.71	43	28	19	12	8.4	5.8	4.0	2.8	1.9	1.4
0.68	0.78	0.80	0.86	0.90	0.93	0.94	32	22	15	10	6.9	4.8	3.4	2.4	1.7	1.2
0.85	0.97	1.00	1.08	1.13	1.16	1.18	23	16	11	7.8	5.5	3.8	2.7	1.9	1.4	1.00
1.02	1.17	1.20	1.30	1.35	1.39	1.42	16	12	8.3	5.9	4.2	3.0	2.2	1.6	1.1	
1.20	1.36	1.40	1.51	1.58	1.62	1.65	11	3.3	6.0	4.3	3.1	2.3	1.7	1.2		
1.37	1.56	1.60	1.73	1.81	1.85	1.89	7.7	6.0	4.2	3.1	2.3	1.7	1.3			
1.54	1.75	1.80	1.94	2.03	2.09	2.12	5.1	4.2	2.9	2.2	1.7	1.3				
1.71	1.95	2.00	2.16	2.26	2.32	2.36	3.4	2.9	2.0	1.6	1.2					
1.88	2.14	2.20	2.38	2.48	2.55	2.59	2.2	2.0	1.4	1.1						
2.05	2.34	2.40	2.59	2.71	2.78	2.83	1.5	1.4								
2.22	2.53	2.60	2.81	2.94	3.01	3.07	1.0									

combination not permitted

I_R Rated ripple current (120 Hz, rms) [A] at upper category temperature T_{uc} taken from data sheet.

I User ripple current [A].

T_a Ambient temperature of capacitor [°C].

L Useful life multiplier.

Regard L as a function of ambient temperature (x-axis) and of current (y-axis); use the current-axis according to the frequency.

LIFETIME TABLE $U_R > 100\text{ V}$

INTERRELATION BETWEEN ALTERNATING CURRENT, AMBIENT TEMPERATURE AND LIFETIME																
I/I_R (FREQUENCY-DEPENDANT)							LIFETIME MULTIPLIER L (DEPENDING ON I/I_R AND T_A)									
CURRENT RATIO I/I_R (DEPENDING ON FREQUENCY)							MULTIPLIER L FOR USEFUL LIFE (DEPENDING ON I/I_R AND T_A)									
50	100	120	250	500	1000	>2500	40	45	50	55	60	65	70	75	80	85
0.00	0.00	0.00	0.00	0.00	0.00	0.00	66	42	27	17	11	7.6	5.1	3.5	2.4	1.7
0.17	0.19	0.20	0.22	0.24	0.25	0.27	62	40	26	17	11	7.4	5.0	3.4	2.4	1.6
0.33	0.39	0.40	0.45	0.48	0.51	0.54	53	35	23	15	9.9	6.7	4.6	3.1	2.2	1.5
0.50	0.58	0.60	0.67	0.72	0.76	0.80	43	28	19	13	8.5	5.8	4.0	2.8	1.9	1.4
0.67	0.77	0.80	0.89	0.96	1.02	1.07	33	22	15	10	7.1	4.9	3.4	2.4	1.7	1.2
0.83	0.97	1.00	1.11	1.20	1.27	1.34	24	17	12	8.1	5.6	3.9	2.8	2.0	1.4	1.00
1.00	1.16	1.20	1.34	1.44	1.53	1.61	17	12	8.7	6.1	4.3	3.1	2.2	1.6	1.1	
1.17	1.36	1.40	1.56	1.68	1.78	1.88	12	8.7	6.3	4.5	3.3	2.4	1.7	1.2		
1.33	1.55	1.60	1.78	1.92	2.03	2.14	8.2	6.1	4.5	3.3	2.4	1.8	1.3			
1.50	1.74	1.80	2.01	2.16	2.29	2.41	5.6	4.2	3.1	2.3	1.7	1.3				
1.67	1.94	2.00	2.23	2.40	2.54	2.68	3.7	2.8	2.2	1.6	1.2					
1.83	2.13	2.20	2.45	2.64	2.80	2.95	2.4	1.9	1.5	1.1						
2.00	2.32	2.40	2.67	2.88	3.05	3.22	1.6	1.3	1.0							
2.17	2.52	2.60	2.90	3.12	3.31	3.48	1.0									

combination not permitted

I_R Rated ripple current (120 Hz, rms) [A] at upper category temperature, taken from data sheet.

I User ripple current [A].

T_a Ambient temperature of capacitor [°C].

L Useful life multiplier.

Regard L as a function of ambient temperature (x-axis) and of current (y-axis); use the current-axis according to the frequency.